

Features

- Accurate 808nm ± 1nm and narrow linewidth
- Stable wavelength versus temperature 0.08nm/°C
- Wavelength locked from 10°C to 70°C
- Typical efficiency 45%

Applications

- Industrial DPSS
- Pico projector laser display

Benefits

- Constant laser power versus temperature
- Athermal pumping
- Increased pumping efficiency



Model Number	4508-0002	4508-0000
Center Wavelength	808 nm	808 nm
Wavelength Tolerance	± 1 nm	± 1 nm
Spectral Width	< 0.5 nm	< 0.5 nm
Output Power	700 mW	2.5 W
Operating Current	< 0.8 A	< 3.5 A
Operating Voltage	< 2.2 V	< 2.2 V
Threshold Current	< 0.25 A	< 0.9 A
Slop Efficiency (@ 1th)	> 0.95 W/A	> 0.95 W/A
Typical Conversion Efficiency	0.45	0.45
Temperature Tuning Coefficient	0.08 nm/°C	0.08 nm/°C
Slow Axis Divergence (FWHM)	< 10 degrees	< 10 degrees
Fast Axis Divergence (FWHM)	< 25 degrees	< 25 degrees
Emitter Width	20 µm	100 µm
Polarization	TE	TE
Mount Type	C-mount	C-mount
Chip Bonding	p-down	p-down

Operating conditions at 20°C unless otherwise noted

Warning: Class 4 Laser, Invisible Laser Radiation – Avoid Eye or Skin Exposure to direct or Scattered Radiation.

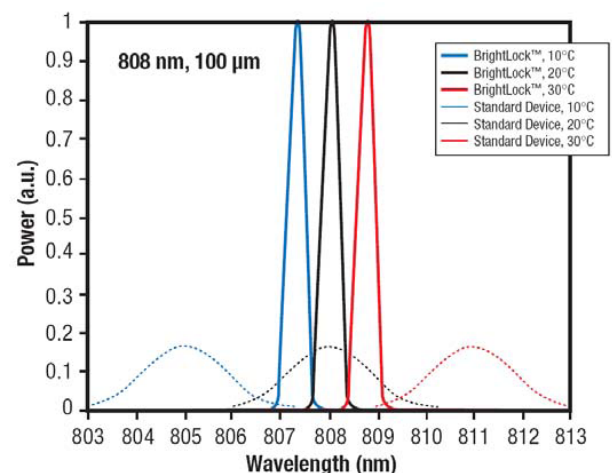
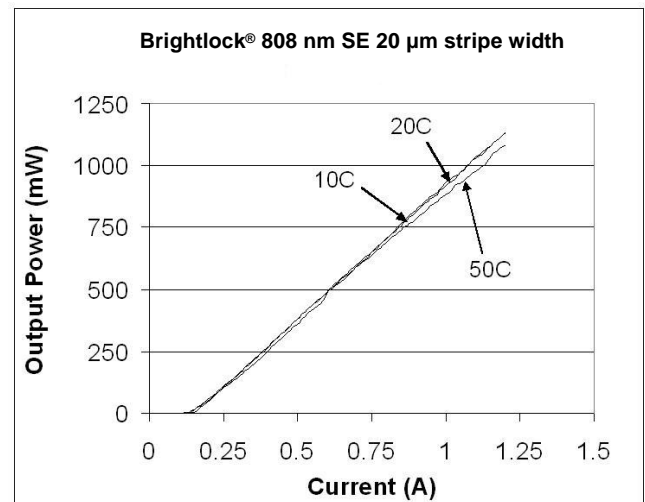

Laser Operations LLC



Mechanical Drawings

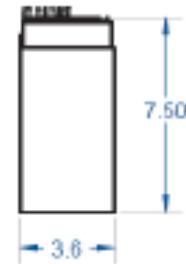
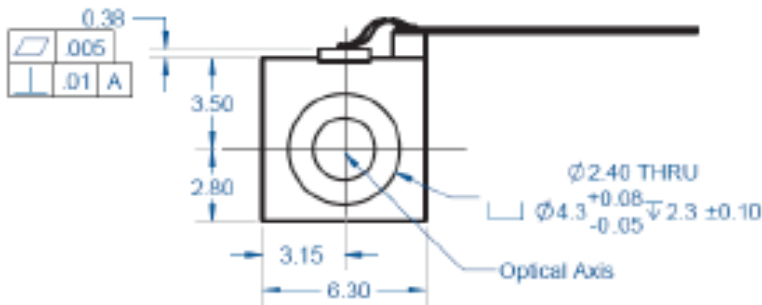
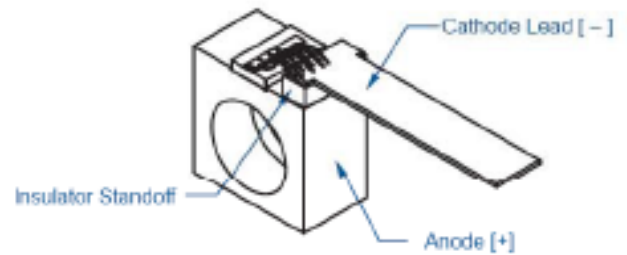
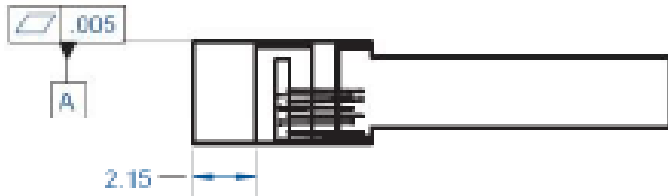

Laser Operations LLC