



# Ultra Therm Thermo-Electric Cooling Module

## Features

- Lightweight
- Dissipates a maximum thermal load of 110 W
- Excellent Temperature Stability
- Feedback Electronics

## Applications

- Forced-air cooling for Ultra Series modules in:
  - Laser products
  - Medical equipment
  - Semi-conductor processing
  - Defense applications

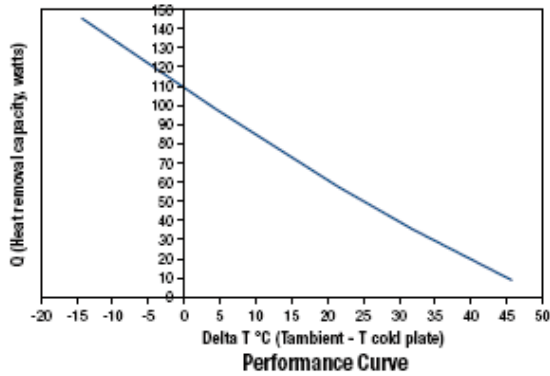

<b>Model Number</b>	<b>9903-0001: Thermo-electric cooling module</b>
Physical dimensions (mm) (LxWxH)	215 x 163.5 x 69.8
Maximum heat dissipation at 20°C	110W
Cooling fan rated voltage (VDC)	24

<b>Model Number</b>	<b>9916-0001: TEC controller</b>
Physical dimensions (mm) (LxWxH)	68.6 x 190.5 x 25.4
Thermistor input	NTC 10kOhm
Power supply requirements	24V, 10A maximum

### Additional Option:

- 9905-0001: TEC controller power supply

Warning: Class 4 Laser, Invisible Laser Radiation – Avoid Eye or Skin Exposure to Direct or Scattered Radiation.



# Ultra Therm Thermo-Electric Cooling Module

Mechanical Drawings of TEC Module with an Ultra-50 Module  
(including aiming beam)

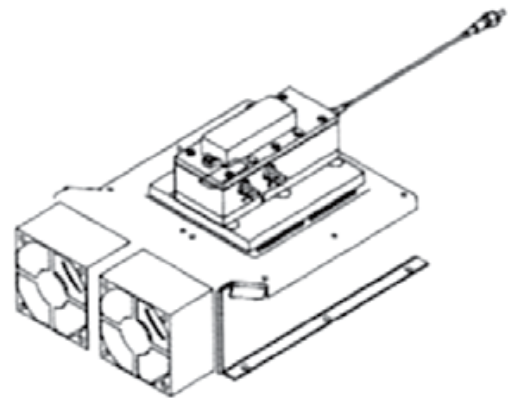
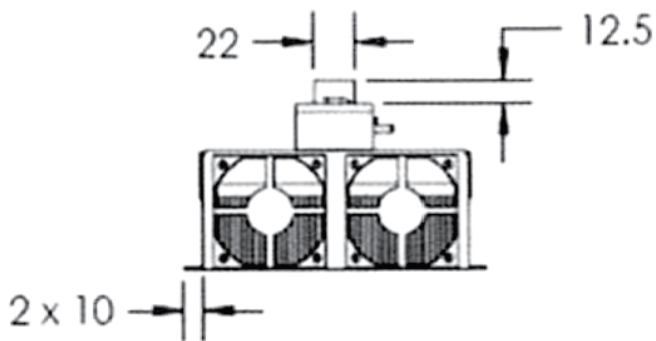
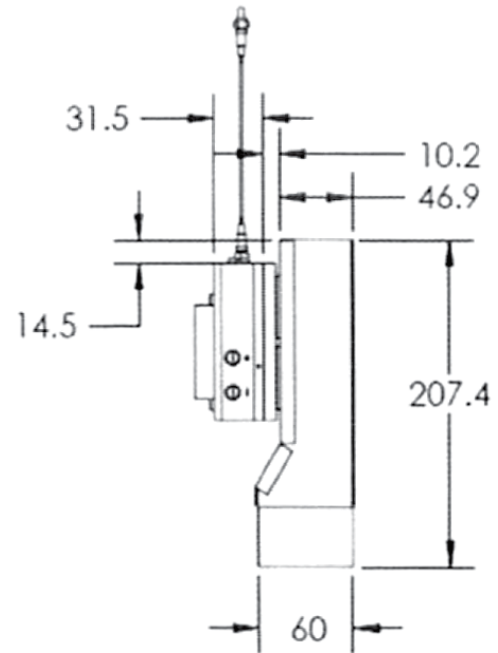
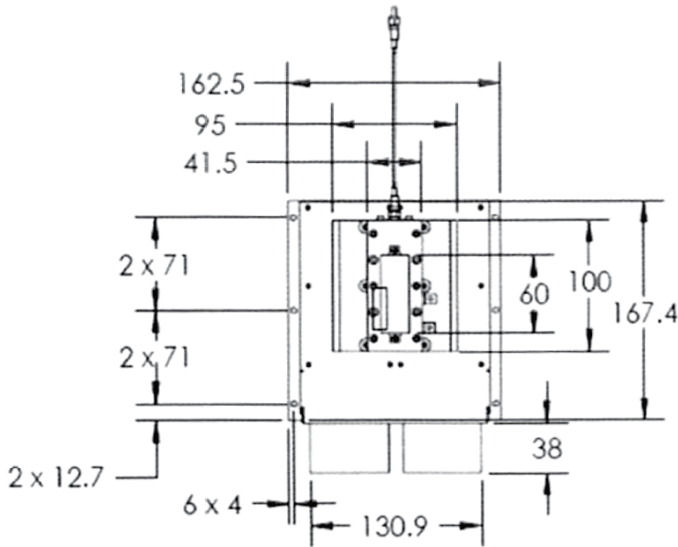

*BRIGHTNESS and POWER*

*Breaking Performance Barriers through Semiconductor Laser Innovation*

Laser Operations LLC

15632 Roxford Street • Sylmar, CA 91342 • Phone + 1(818) 986-0000 • Fax: +1(818) 698-0428

www.QPCLasers.com • email: info@laseroperations.net